

Ferramenta fornita con il contenitore

spina legno  n°18	reggipiano  n°12
barilotto P18 e P25  n°12	piede regolabile  n°4
tirante  n°12	bullone  n°4

Fig.1 - posizionamento spine e tiranti

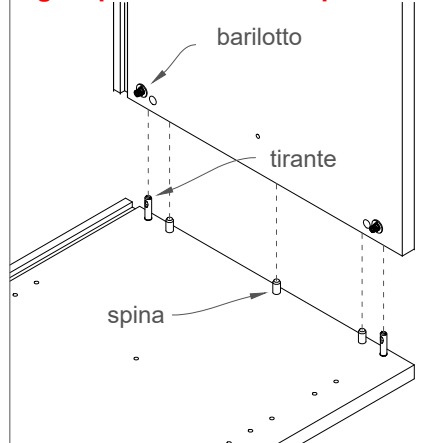
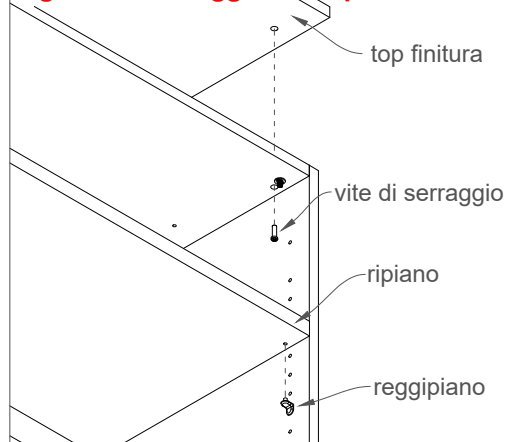
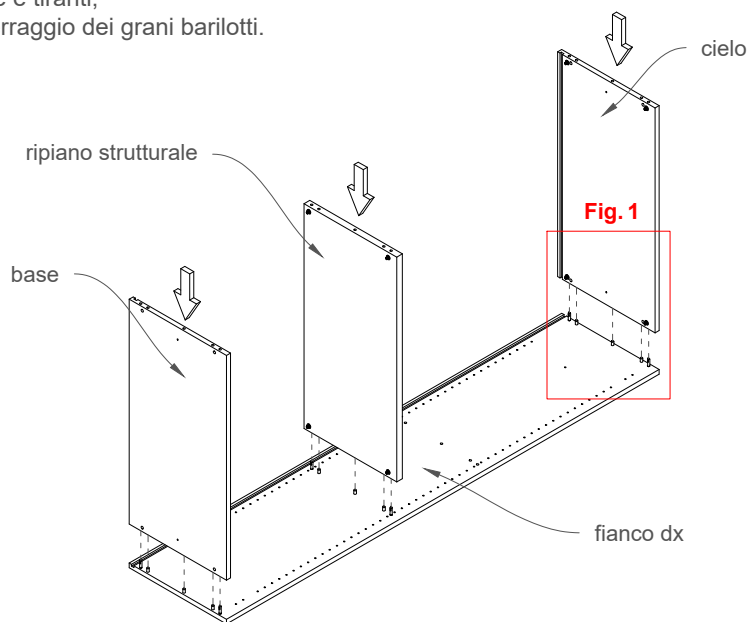

Fig.2 - viti serraggio del top finitura



- 1) posizionare in orizzontale il fianco dx o sx;
- 2) unire cielo, base e ripiano strutturale al fianco in corrispondenza dei fori spine e tiranti;
- 3) serraggio dei grani barilotti.



- 5) unire il fianco in corrispondenza dei fori per chiudere l'intera carcassa;
- 6) serraggio dei grani barilotti;
- 7) inserire i piedi regolabili alla base.

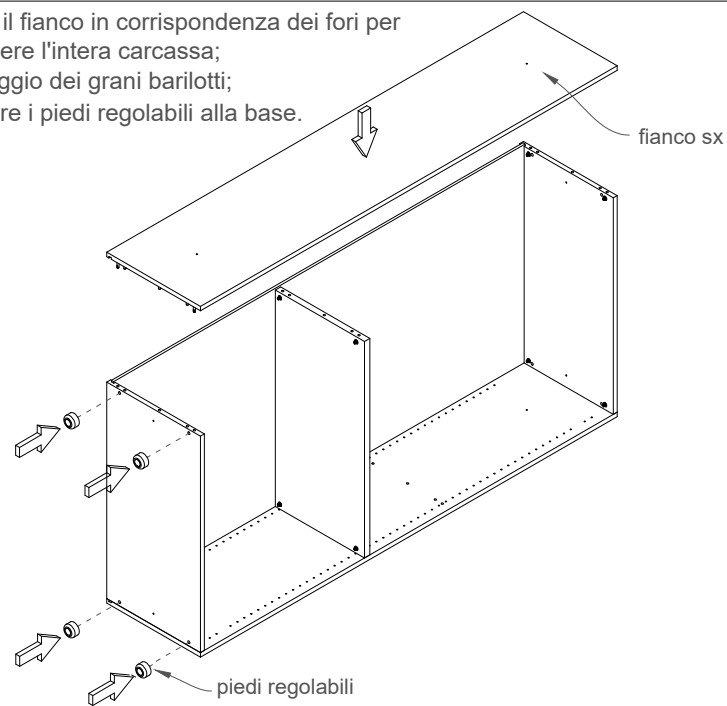

- 4) inserire la schiena negli scassi.

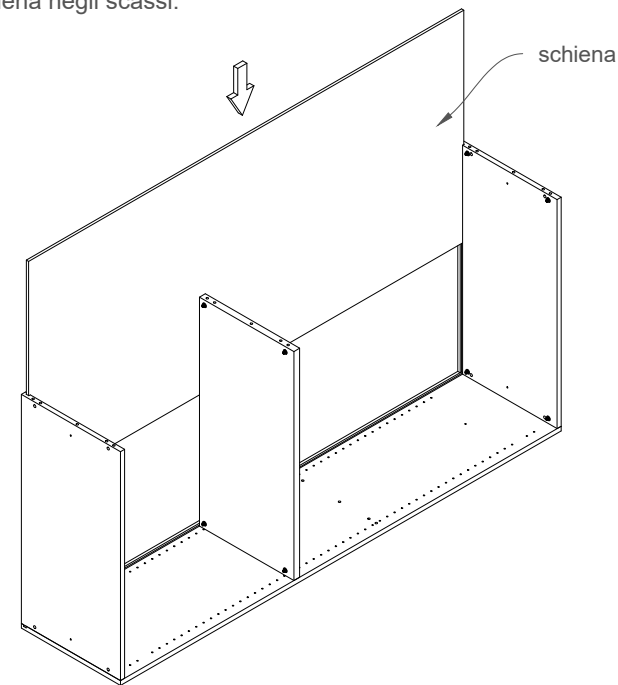

- 8) unire il top al cielo in corrispondenza dei fori;
- 9) serraggio viteria;
- 10) inserire reggipiani nei fori dei fianchi e posizionare i ripiani.

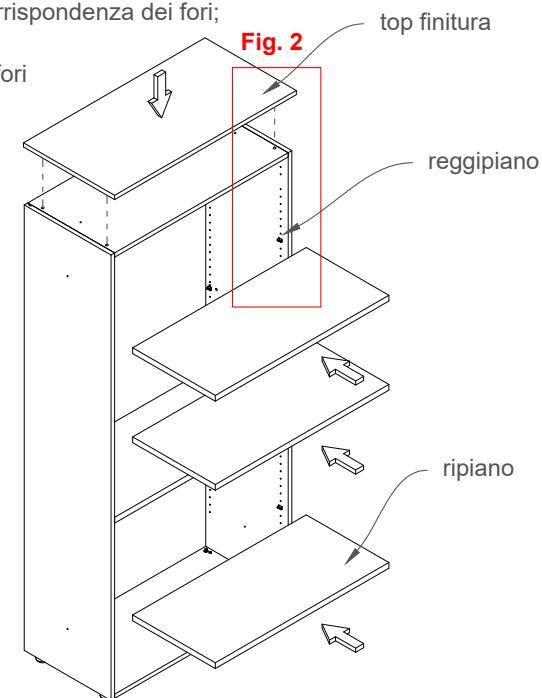

Ferramenta fornita con le ante

basetta cerniera n°8	viti per cerniere e serratura n°18
viti per basetta n°16	cerniera n°8
cerniera n°8	maniglie per ante n°2
serratura a chiave n°1	viti per maniglie n°4

Fig.1 - posizionamento basetta/cerniera

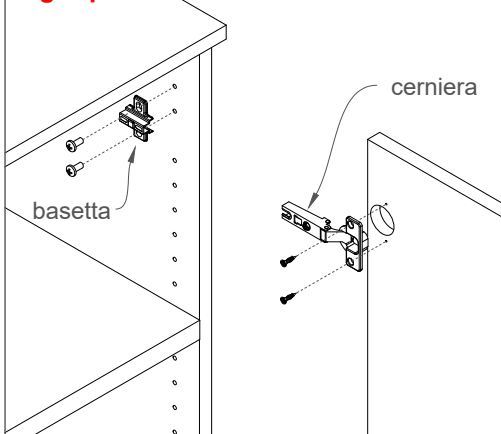
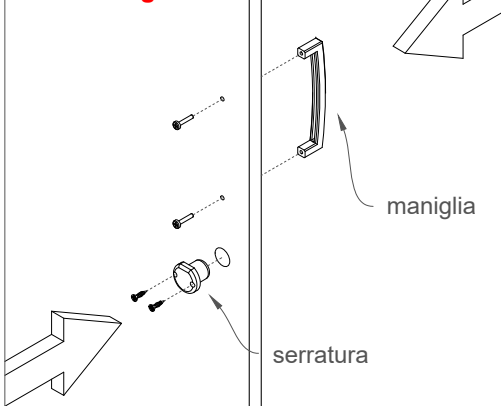
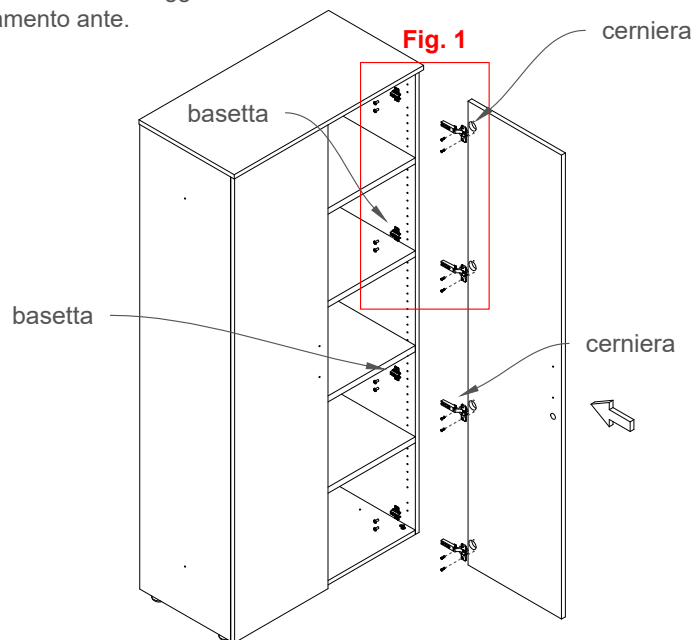

Fig.2 - posizionamento serratura e maniglia



- 11) posizionamento e fissaggio delle basette;
- 12) posizionamento e fissaggio delle cerniere.
- 13) alloggiamento ante.



- 14) alloggiamento serratura e posizionamento maniglia;
- 15) regolazione delle chiusure ante.

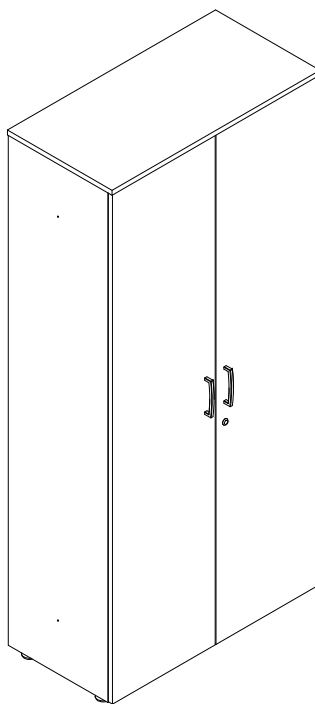
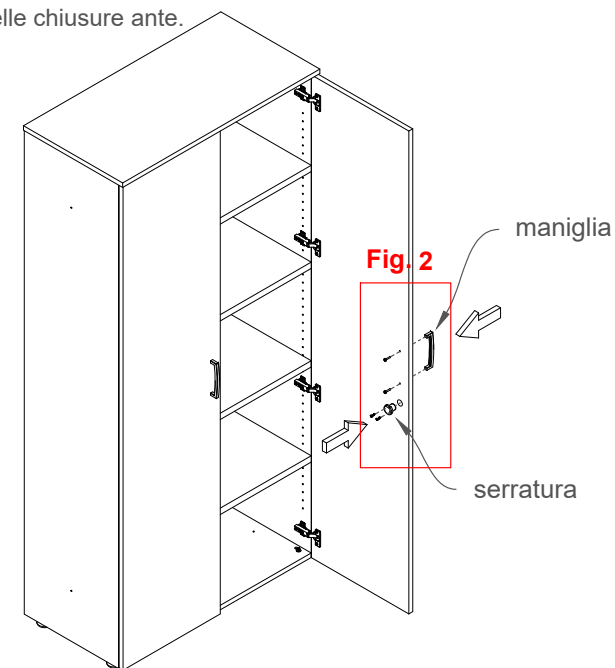

Contattaci per ogni bisogno

Numero Verde Gratuito
800 72 12 69

@ info@oneufficio.it

 327 7603038